

# EXGJH and EXLK Flexible Couplings

## Explosionproof, Dust-Ignitionproof

UNILETS™ for Use with Threaded Rigid Metal Conduit and IMC.

NEC/CEC — 1/2" and 3/4" Sizes:  
Class I, Groups A, B, C, D  
Class II, Groups E, F, G  
Class III

NEC/CEC — 1" Size:  
Class I, Groups C, D  
Class II, Groups E, F, G  
Class III

NEC/CEC — 1-1/4" thru 4" Sizes:  
Class I, Group D  
Class II, Groups E, F, G  
Class III

ATEX: — stainless steel 1/2" thru  
2" Sizes:  
Ex d IIC GD  
Ex t IIC Db  
IP66

### Applications

- Used in areas where vibration and/or movement is a problem. Also used in place of rigid conduit in difficult-bend situations.

### Features

- Explosionproof, dust-ignitionproof, watertight
- Smooth, rounded integral bushing in each hub protects conductor insulation.
- Accurately tapped, tapered threads for tight, rigid joints and ground continuity.
- Heavy duty design resists mechanical abuse.
- Electrical conductivity equal to rigid conduit on a similar length basis—no bonding jumper required.
- Interior insulating liner protects conductors from abrasion under vibrating conditions.
- EXGJH: both end fittings are female, each furnished with a removable male nipple.
- EXLK: female end fitting with union at one end and a female end fitting with a removable male nipple at the other end.

### Standard Materials

- 1/2" thru 2": outer bronze braid, inner brass core with insulating liner
- 2-1/2" thru 4": outer stainless steel braid, inner stainless steel core with insulating liner
- End Fittings: 1/2" thru 2"—brass; 2-1/2" thru 4"—stainless steel
- Unions: 1/2" thru 1" zinc plated steel; 1-1/4" thru 2" ductile iron
- Close nipples: zinc plated steel

### Standard Finishes

- Natural finish

### Options

- 1/2" through 2" available in stainless steel. Add suffix **-SS**. EXLK Union is zinc plated steel. Stainless steel union available in 1/2" through 1". Add suffix **-SU**.
- Close nipples are zinc plated steel. For 1/2" through 1" stainless steel nipple. Add suffix **-NS**
- Custom lengths available—consult factory

### NEC/CEC Certifications and Compliances

- UL Standard: 886 (1203)
- UL Listed: E10444
- CSA Standard: C22.2 No. 25, C22.2 No. 30
- CSA Certified: 065181

### ATEX Certifications and Compliances

- Certification Type FLEXCO (*Excludes Nipples and Unions*)
  - Gas, Zones 1 and 2:
    - Conforming to ATEX 94/9/EC: Ex II 2G
    - Type of Protection: Ex d IIC Gb
  - Dusts, Zones 21 and 22:
    - Conforming to ATEX: Ex II 2D
    - Type of Protection: Ex t IIC Db
- Ambient Temperatures: -40 °C ≤ to ≤ + 150 °C (-40 °F ≤ to ≤ + 302 °F)
- Ex Standards: EN 60079-0, 60079-1, EN 60079-31
- ATEX Certificate : LCIE 11 ATEX 3006U
- Index of Protection according EN/IEC 60529: IP66



EXGJH

Suitable for Wet Locations – Two Removal Male Nipples



EXLK

One Removal Male Nipple, One Removable Union

# EXGJH and EXLK Flexible Couplings

## Explosionproof, Dust-Ignitionproof

UNILETS™ for Use with Threaded Rigid Metal Conduit and IMC.

NEC/CEC — 1/2" and 3/4" Sizes:  
Class I, Groups A, B, C, D  
Class II, Groups E, F, G  
Class III

NEC/CEC — 1" Size:  
Class I, Groups C, D  
Class II, Groups E, F, G  
Class III

NEC/CEC — 1-1/4" thru 4" Sizes:  
Class I, Group D  
Class II, Groups E, F, G  
Class III

ATEX: — stainless steel 1/2" thru  
2" Sizes:  
Ex d IIC Gb  
Ex t IIIC Db  
IP66

Size (Inches)		Catalog Number	
Flex Length	Diameter Size	EXGJH	EXLK
4	1/2	EXGJH-14 ◊	EXLK-14 ◊
4	3/4	EXGJH-24 ◊	EXLK-24 ◊
6	1/2	EXGJH-16 ◊	EXLK-16 ◊
6	3/4	EXGJH-26 ◊	EXLK-26 ◊
6	1	EXGJH-36	EXLK-36
8	1/2	EXGJH-18 ◊	EXLK-18 ◊
8	3/4	EXGJH-28 ◊	EXLK-28 ◊
8	1	EXGJH-38	EXLK-38
10	1/2	EXGJH-110 ◊	EXLK-110 ◊
10	3/4	EXGJH-210 ◊	EXLK-210 ◊
10	1	EXGJH-310	EXLK-310
12	1/2	EXGJH-112 ◊	EXLK-112 ◊
12	3/4	EXGJH-212 ◊	EXLK-212 ◊
12	1	EXGJH-312	EXLK-312
12	1-1/4	EXGJH-412	EXLK-412
12	1-1/2	EXGJH-512	EXLK-512
12	2	EXGJH-612	EXLK-612
12	2-1/2	EXGJH-712	
12	3	EXGJH-812	
12	4	EXGJH-1012	
15	1/2	EXGJH-115 ◊	EXLK-115 ◊
15	3/4	EXGJH-215 ◊	EXLK-215 ◊
15	1	EXGJH-315	EXLK-315
15	1-1/4	EXGJH-415	EXLK-415
15	1-1/2	EXGJH-515	EXLK-515
15	2	EXGJH-615	EXLK-615
15	2-1/2	EXGJH-715	
15	3	EXGJH-815	
15	4	EXGJH-1015	
18	1/2	EXGJH-118 ◊	EXLK-118 ◊
18	3/4	EXGJH-218 ◊	EXLK-218 ◊
18	1	EXGJH-318	EXLK-318
18	1-1/4	EXGJH-418	EXLK-418
18	1-1/2	EXGJH-518	EXLK-518
18	2	EXGJH-618	EXLK-618
18	2-1/2	EXGJH-718	
18	3	EXGJH-818	
18	4	EXGJH-1018	
21	1/2	EXGJH-121 ◊	EXLK-121 ◊
21	3/4	EXGJH-221 ◊	EXLK-221 ◊
21	1	EXGJH-321	EXLK-321
21	1-1/4	EXGJH-421	EXLK-421
21	1-1/2	EXGJH-521	EXLK-521
21	2	EXGJH-621	EXLK-621
21	2-1/2	EXGJH-721	
21	3	EXGJH-821	
21	4	EXGJH-1021	

Size (Inches)		Catalog Number	
Flex Length	Diameter Size	EXGJH	EXLK
24	1/2	EXGJH-124 ◊	EXLK-124 ◊
24	3/4	EXGJH-224 ◊	EXLK-224 ◊
24	1	EXGJH-324	EXLK-324
24	1-1/4	EXGJH-424	EXLK-424
24	1-1/2	EXGJH-524	EXLK-524
24	2	EXGJH-624	EXLK-624
24	2-1/2	EXGJH-724	—
24	3	EXGJH-824	—
24	4	EXGJH-1024	—
27	1/2	EXGJH-127 ◊	EXLK-127 ◊
27	3/4	EXGJH-227 ◊	EXLK-227 ◊
27	1	EXGJH-327	EXLK-327
27	1-1/4	EXGJH-427	EXLK-427
27	1-1/2	EXGJH-527	EXLK-527
27	2	EXGJH-627	EXLK-627
27	2-1/2	EXGJH-727	
27	3	EXGJH-827	
27	4	EXGJH-1027	
30	1/2	EXGJH-130 ◊	EXLK-130 ◊
30	3/4	EXGJH-230 ◊	EXLK-230 ◊
30	1	EXGJH-330	EXLK-330
30	1-1/4	EXGJH-430	EXLK-430
30	1-1/2	EXGJH-530	EXLK-530
30	2	EXGJH-630	EXLK-630
30	2-1/2	EXGJH-730	
30	3	EXGJH-830	
30	4	EXGJH-1030	
33	1/2	EXGJH-133 ◊	EXLK-133 ◊
33	3/4	EXGJH-233 ◊	EXLK-233 ◊
33	1	EXGJH-333	EXLK-333
33	1-1/4	EXGJH-433	EXLK-433
33	1-1/2	EXGJH-533	EXLK-533
33	2	EXGJH-633	EXLK-633
33	2-1/2	EXGJH-733	
33	3	EXGJH-833	
33	4	EXGJH-1033	
36	1/2	EXGJH-136 ◊	EXLK-136 ◊
36	3/4	EXGJH-236 ◊	EXLK-236 ◊
36	1	EXGJH-336	EXLK-336
36	1-1/4	EXGJH-436	EXLK-436
36	1-1/2	EXGJH-536	EXLK-536
36	2	EXGJH-636	EXLK-636
36	2-1/2	EXGJH-736	
36	3	EXGJH-836	
36	4	EXGJH-1036	

NOTE: Unions are not available in stainless steel.

◊ Indicates items in the shaded area which are UL Listed for Class I, Groups A, B, C, D; Class II, Groups E, F, G; Class III.

HAZARDOUS LOCATION FITTINGS: NEC/CEC EXPLOSIONPROOF CONDUIT FITTINGS



# EXGJH and EXLK Flexible Couplings

Explosionproof, Dust-Ignitionproof, Watertight

UNILETS™ for Use with Threaded Rigid Metal Conduit and IMC.

NEC/CEC — 1/2" and 3/4" Sizes:  
Class I, Groups A, B, C, D  
Class II, Groups E, F, G  
Class III

NEC/CEC — 1" Size:  
Class I, Groups C, D  
Class II, Groups E, F, G  
Class III

NEC/CEC — 1-1/4" thru 4" Sizes:  
Class I, Group D  
Class II, Groups E, F, G  
Class III

ATEX: — stainless steel 1/2" thru  
2" Sizes:  
Ex II 2 GD  
Ex d IIC Gb  
Ex t IIIC Db  
IP66

HAZARDOUS LOCATION FITTINGS: NEC/CEC EXPLOSIONPROOF CONDUIT FITTINGS

## EXGJH and EXLK Dimensions in Millimeters (Inches)

Coupling Size	A	B	C	D	E	Bending Radius ①
1/2	63.5 (2.50)	34.9 (1.38)	76.2 (3.00)	35.7 (1.41)	37.3 (1.47)	254.0 (10.00)
3/4	65.0 (2.56)	34.9 (1.38)	82.6 (3.25)	44.5 (1.75)	44.5 (1.75)	304.8 (12.00)
1	51.6 (2.03)	44.5 (1.75)	92.1 (3.63)	52.4 (2.06)	50.8 (2.00)	355.6 (14.00)
1-1/4	84.1 (3.31)	51.6 (2.03)	111.1 (4.38)	66.7 (2.63)	71.4 (2.81)	406.4 (16.00)
1-1/2	95.3 (3.75)	55.6 (2.19)	115.9 (4.56)	79.4 (3.13)	77.8 (3.06)	406.4 (16.00)
2	106.4 (4.19)	61.9 (2.44)	125.4 (4.94)	98.4 (3.88)	94.5 (3.72)	457.2 (18.00)
2-1/2	112.8 (4.44)	66.7 (2.63)	158.8 (6.25)	114.3 (4.50)	123.8 (4.88)	381.0 (15.00)
3	113.5 (4.47)	66.7 (2.63)	158.8 (6.25)	127.8 (5.03)	136.5 (5.38)	584.2 (23.00)
4	115.1 (4.53)	66.7 (2.63)	161.9 (6.38)	168.3 (6.63)	163.5 (6.44)	1219.2 (48.00)

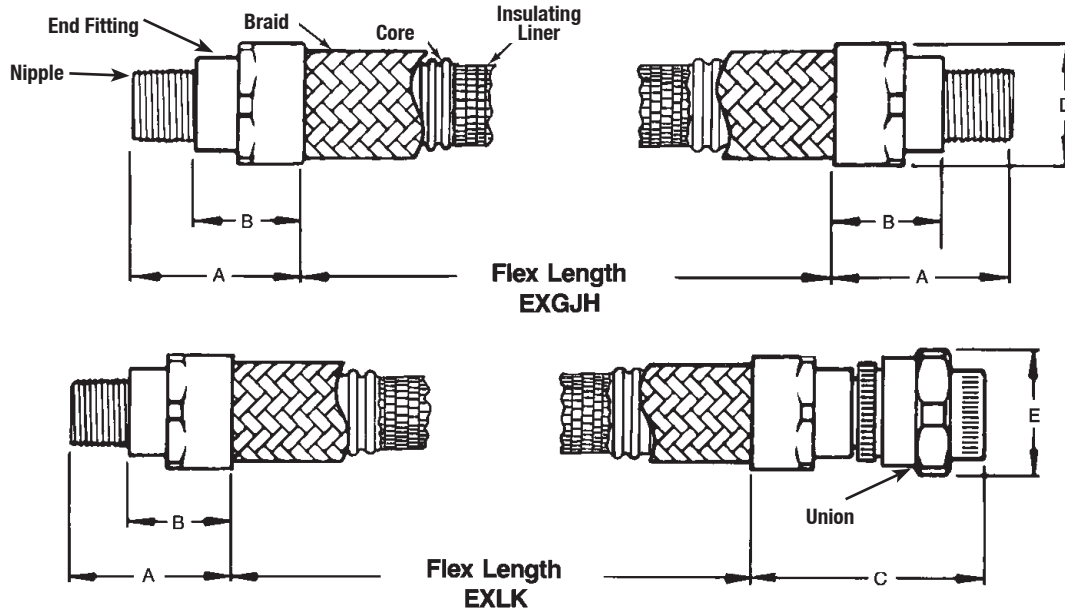

① Bending Radius shown is minimum recommended.

# ECGJH and ECLK Flexible Couplings

## Explosionproof, Dust-Ignitionproof

For Use with Threaded Rigid Metal Conduit and IMC.

### NEC/CEC — 1/2" and 3/4" Sizes:

Class I, Division 1 and 2, Groups A, B, C, D  
Class I, Zone 1 and 2, Groups IIA, IIB, IIC  
Class II, Division 1 and 2, Groups E, F, G  
Class III

### NEC/CEC — 1" Size:

Class I, Division 1 and 2, Groups C, D  
Class I, Zone 1 and 2, Groups IIA, IIB  
Class II, Division 1 and 2, Groups E, F, G  
Class III

### NEC/CEC — 1-1/4" thru 4" Sizes:

Class I, Division 1 and 2, Group D  
Class I, Zone 1 and 2, Group IIA  
Class II, Division 1 and 2, Groups E, F, G  
Class III

## Applications

- Used in areas where vibration and/or movement is a problem. Also used in place of rigid conduit in difficult-bend situations.

## Features

- Explosionproof, dust-ignitionproof, watertight
- Smooth, rounded integral bushing in each hub protects conductor insulation.
- Accurately tapped, tapered threads for tight, rigid joints and ground continuity.
- Heavy duty design resists mechanical abuse.
- Electrical conductivity equal to rigid conduit on a similar length basis—no bonding jumper required.
- Interior insulating liner protects conductors from abrasion under vibrating conditions.
- ECGJH: both end fittings are female, each furnished with a removable male nipple.
- ECLK: female end fitting with union at one end and a female end fitting with a removable male nipple at the other end.

## Standard Materials

- Flexible coupling is constructed from brass tubing and bronze outer braid, with insulating liner
- 1/2" - 1" trade size  
Bronze end fittings with zinc plated steel UNF female union on one end and steel close nipple on the other
- 1-1/4" - 2" trade size  
Bronze end fittings with malleable iron UNF female union on one end and steel close nipple on other end
- Unions: 1/2" thru 1" zinc plated steel; 1-1/4" thru 2" ductile iron
- Close nipples: zinc plated steel

## Standard Finishes

- Natural finish

## Options

- 1/2" through 2" available in stainless steel. Add suffix **-SS**. ECLK Union is zinc plated steel. Stainless steel union available in 1/2" through 1". Add suffix **-SU**.
- Close nipples are zinc plated steel. For 1/2" through 1" stainless steel nipple. Add suffix **-NS**
- Custom lengths available—consult factory

## NEC/CEC Certifications and Compliances

- UL Standard: 886
- UL Listed: E-34997 ①
- CSA Standard: C22.2 No. 30
- CSA Certified: 009795 ①
- NEC Articles 500-503 and 505
- Suitable for wet locations



**ECGJH**  
Suitable for Wet Locations – Two Removal Male Nipples



**ECLK**  
One Removal Male Nipple, One Removable Union

① UL Listing and CSA Certification not applicable over 2" Trade Size.

# ECGJH and ECLK Flexible Couplings

## Explosionproof, Dust-Ignitionproof

For Use with Threaded Rigid Metal Conduit and IMC.

**NEC/CEC — 1/2" and 3/4" Sizes:**  
 Class I, Division 1 and 2, Groups A, B, C, D  
 Class I, Zone 1 and 2, Groups IIA, IIB, IIC  
 Class II, Division 1 and 2, Groups E, F, G  
 Class III

**NEC/CEC — 1" Size:**  
 Class I, Division 1 and 2, Groups C, D  
 Class I, Zone 1 and 2, Groups IIA, IIB  
 Class II, Division 1 and 2, Groups E, F, G  
 Class III

**NEC/CEC — 1-1/4" thru 4" Sizes:**  
 Class I, Division 1 and 2, Group D  
 Class I, Zone 1 and 2, Group IIA  
 Class II, Division 1 and 2, Groups E, F, G  
 Class III

HAZARDOUS LOCATION FITTINGS: NEC/CEC EXPLOSIONPROOF CONDUIT FITTINGS

OZGEDNEY

Size (Inches)		Catalog Number	
Flex Length	Diameter Size	ECGJH	ECLK
4	1/2	ECGJH-50-4 ◊	ECLK-50-4 ◊
4	3/4	ECGJH-75-4 ◊	ECLK-75-4 ◊
6	1/2	ECGJH-50-6 ◊	ECLK-50-6 ◊
6	3/4	ECGJH-75-6 ◊	ECLK-75-6 ◊
6	1	ECGJH-100-6	ECLK-100-6
8	1/2	ECGJH-50-8 ◊	ECLK-50-8 ◊
8	3/4	ECGJH-75-8 ◊	ECLK-75-8 ◊
8	1	ECGJH-100-8	ECLK-100-8
10	1/2	ECGJH-50-10 ◊	ECLK-50-10 ◊
10	3/4	ECGJH-75-10 ◊	ECLK-75-10 ◊
10	1	ECGJH-100-10	ECLK-100-10
12	1/2	ECGJH-50-12 ◊	ECLK-50-12 ◊
12	3/4	ECGJH-75-12 ◊	ECLK-75-12 ◊
12	1	ECGJH-100-12	ECLK-100-12
12	1-1/4	ECGJH-125-12	ECLK-125-12
12	1-1/2	ECGJH-150-12	ECLK-150-12
12	2	ECGJH-200-12	ECLK-200-12
12	2-1/2	ECGJH-250-12	
12	3	ECGJH-300-12	
12	4	ECGJH-400-12	
15	1/2	ECGJH-50-15 ◊	ECLK-50-15 ◊
15	3/4	ECGJH-75-15 ◊	ECLK-75-15 ◊
15	1	ECGJH-100-15	ECLK-100-15
15	1-1/4	ECGJH-125-15	ECLK-125-15
15	1-1/2	ECGJH-150-15	ECLK-150-15
15	2	ECGJH-200-15	ECLK-200-15
15	2-1/2	ECGJH-250-15	
15	3	ECGJH-300-15	
15	4	ECGJH-400-15	
18	1/2	ECGJH-50-18 ◊	ECLK-50-18 ◊
18	3/4	ECGJH-75-18 ◊	ECLK-75-18 ◊
18	1	ECGJH-100-18	ECLK-100-18
18	1-1/4	ECGJH-125-18	ECLK-125-18
18	1-1/2	ECGJH-150-18	ECLK-150-18
18	2	ECGJH-200-18	ECLK-200-18
18	2-1/2	ECGJH-250-18	
18	3	ECGJH-300-18	
18	4	ECGJH-400-18	
21	1/2	ECGJH-50-21 ◊	ECLK-50-21 ◊
21	3/4	ECGJH-75-21 ◊	ECLK-75-21 ◊
21	1	ECGJH-100-21	ECLK-100-21
21	1-1/4	ECGJH-125-21	ECLK-125-21
21	1-1/2	ECGJH-150-21	ECLK-150-21
21	2	ECGJH-200-21	ECLK-200-21
21	2-1/2	ECGJH-250-21	
21	3	ECGJH-300-21	
21	4	ECGJH-400-21	

Size (Inches)		Catalog Number	
Flex Length	Diameter Size	ECGJH	ECLK
24	1/2	ECGJH-50-24 ◊	ECLK-50-24 ◊
24	3/4	ECGJH-75-24 ◊	ECLK-75-24 ◊
24	1	ECGJH-100-24	ECLK-100-24
24	1-1/4	ECGJH-125-24	ECLK-125-24
24	1-1/2	ECGJH-150-24	ECLK-150-24
24	2	ECGJH-200-24	ECLK-200-24
24	2-1/2	ECGJH-250-24	—
24	3	ECGJH-300-24	—
24	4	ECGJH-400-24	—
27	1/2	ECGJH-50-27 ◊	ECLK-50-27 ◊
27	3/4	ECGJH-75-27 ◊	ECLK-75-27 ◊
27	1	ECGJH-100-27	ECLK-100-27
27	1-1/4	ECGJH-125-27	ECLK-125-27
27	1-1/2	ECGJH-150-27	ECLK-150-27
27	2	ECGJH-200-27	ECLK-200-27
27	2-1/2	ECGJH-250-27	
27	3	ECGJH-300-27	
27	4	ECGJH-400-27	
30	1/2	ECGJH-50-30 ◊	ECLK-50-30 ◊
30	3/4	ECGJH-75-30 ◊	ECLK-75-30 ◊
30	1	ECGJH-100-30	ECLK-100-30
30	1-1/4	ECGJH-125-30	ECLK-125-30
30	1-1/2	ECGJH-150-30	ECLK-150-30
30	2	ECGJH-200-30	ECLK-200-30
30	2-1/2	ECGJH-250-30	
30	3	ECGJH-300-30	
30	4	ECGJH-400-30	
33	1/2	ECGJH-50-33 ◊	ECLK-50-33 ◊
33	3/4	ECGJH-75-33 ◊	ECLK-75-33 ◊
33	1	ECGJH-100-33	ECLK-100-33
33	1-1/4	ECGJH-125-33	ECLK-125-33
33	1-1/2	ECGJH-150-33	ECLK-150-33
33	2	ECGJH-200-33	ECLK-200-33
33	2-1/2	ECGJH-250-33	
33	3	ECGJH-300-33	
33	4	ECGJH-400-33	
36	1/2	ECGJH-50-36 ◊	ECLK-50-36 ◊
36	3/4	ECGJH-75-36 ◊	ECLK-75-36 ◊
36	1	ECGJH-100-36	ECLK-100-36
36	1-1/4	ECGJH-125-36	ECLK-125-36
36	1-1/2	ECGJH-150-36	ECLK-150-36
36	2	ECGJH-200-36	ECLK-200-36
36	2-1/2	ECGJH-250-36	
36	3	ECGJH-300-36	
36	4	ECGJH-400-36	

NOTE: Unions are not available in stainless steel.

◊ Indicates items in the shaded area which are UL Listed for Class I, Groups A, B, C, D; Class II, Groups E, F, G; Class III.

# ECGJH and ECLK Flexible Couplings

## Explosionproof, Dust-Ignitionproof, Watertight

For Use with Threaded Rigid Metal Conduit and IMC.

**NEC/CEC — 1/2" and 3/4" Sizes:**  
 Class I, Division 1 and 2, Groups A, B, C, D  
 Class I, Zone 1 and 2, Groups IIA, IIB, IIC  
 Class II, Division 1 and 2, Groups E, F, G  
 Class III

**NEC/CEC — 1" Size:**  
 Class I, Division 1 and 2, Groups C, D  
 Class I, Zone 1 and 2, Groups IIA, IIB  
 Class II, Division 1 and 2, Groups E, F, G  
 Class III

**NEC/CEC — 1-1/4" thru 4" Sizes:**  
 Class I, Division 1 and 2, Group D  
 Class I, Zone 1 and 2, Group IIA  
 Class II, Division 1 and 2, Groups E, F, G  
 Class III

ECGJH and ECLK Dimensions in Millimeters (Inches)

Coupling Size (Inches)	A	B	C	D	E	Bending Radius ①
1/2	63.5 (2.50)	34.9 (1.38)	76.2 (3.00)	35.7 (1.41)	37.3 (1.47)	254.0 (10.00)
3/4	65.0 (2.56)	34.9 (1.38)	82.6 (3.25)	44.5 (1.75)	44.5 (1.75)	304.8 (12.00)
1	51.6 (2.03)	44.5 (1.75)	92.1 (3.63)	52.4 (2.06)	50.8 (2.00)	355.6 (14.00)
1-1/4	84.1 (3.31)	51.6 (2.03)	111.1 (4.38)	66.7 (2.63)	71.4 (2.81)	406.4 (16.00)
1-1/2	95.3 (3.75)	55.6 (2.19)	115.9 (4.56)	79.4 (3.13)	77.8 (3.06)	406.4 (16.00)
2	106.4 (4.19)	61.9 (2.44)	125.4 (4.94)	98.4 (3.88)	94.5 (3.72)	457.2 (18.00)
2-1/2	112.8 (4.44)	66.7 (2.63)	158.8 (6.25)	114.3 (4.50)	123.8 (4.88)	381.0 (15.00)
3	113.5 (4.47)	66.7 (2.63)	158.8 (6.25)	127.8 (5.03)	136.5 (5.38)	584.2 (23.00)
4	115.1 (4.53)	66.7 (2.63)	161.9 (6.38)	168.3 (6.63)	163.5 (6.44)	1219.2 (48.00)

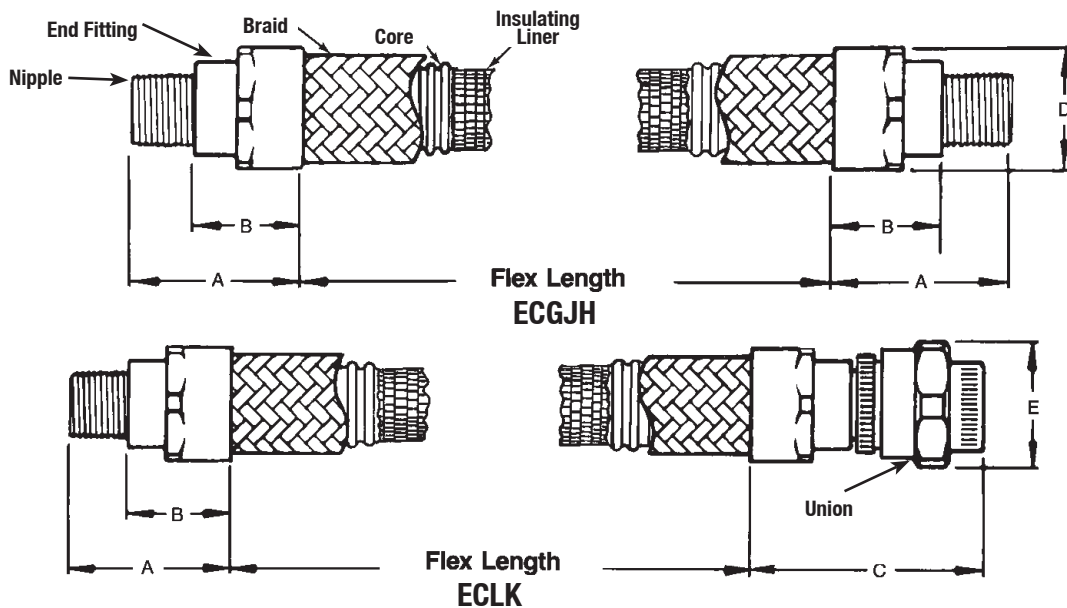

① Bending Radius shown is minimum recommended.